

MP3-H Series Overview

Description

Cosmau MP3-H series multiple passage rotary unions with 3 channel for media transfer, design for oil, water and coolant in rotating system.

- Transmit hydraulic oil, water and coolant when 360°unrestricted rotation
- Combined with electrical slip ring,transfer power,control signal, data
- Through hole or flange structure optional
- Available all kinds of custom solutions



Specifications

Item	
Pneumatic Channel	3
Pressure	Max. 350bar
Connection Szie	1/8" 1/4", 3/8", 1/2", 3/4", 1"
Connection Type	BSPB
Operating Temperature	-18° C to 150° C
Suitable Media	Oil / Water / Coolant
Speed	Max. 300 RPM
Material	AL alloy housing, Carbon Steel / Stainless Steel Shaft

Note: All values listed under Technical Specifications are dependent on a combination of all application parameters. Please note service life is dependent upon both rotational speed and duty cycle.

Options

- Mounting Flange / Through Hole
- Connection Size
- Connection Type
- Material
- Pressure
- Media
- Optional Speed
- Combine with electrical slip ring

INTRODUCE

MP3-H

5

MP3-H Series Dimensions

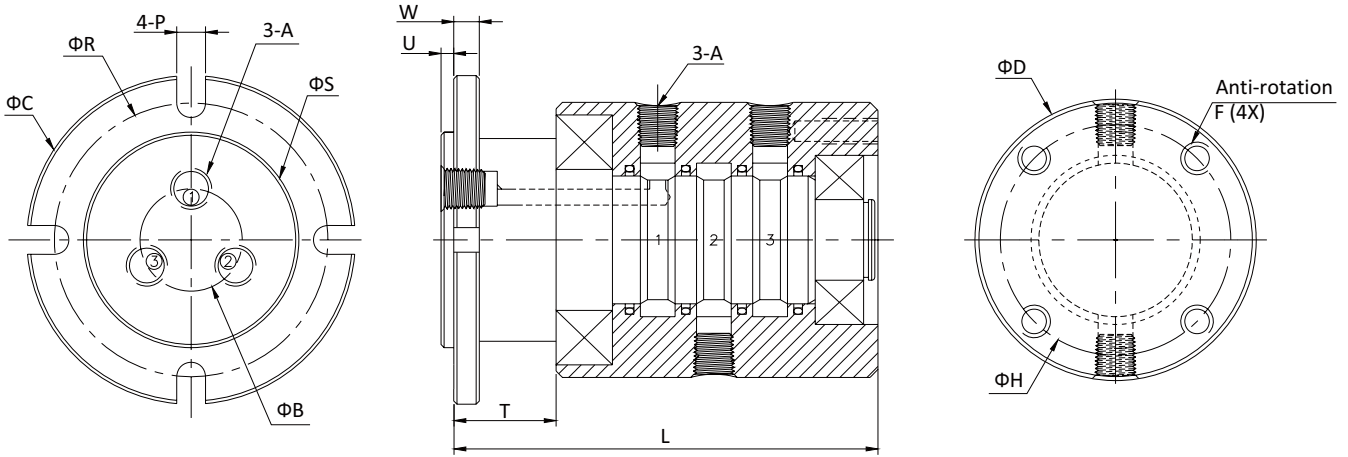

Part#	A(BSPP/NPT)	ΦB	ΦC	ΦD	ΦR	ΦS	U	W	T	P	F	ΦH	L
MP-301-H	1/8"	25	69.5	69.5	59	46	3	6	24	6.5	M6	59	131.4
MP-302-H	1/4"	26	74.5	74.5	64	51	3	6	24	6.5	M6	64	135.4
MP-303-H	3/8"	29.5	79.5	79.5	69	57	3	6	24	6.5	M6	69	149.9
MP-304-H	1/2"	36	94.5	94.5	81.5	67.5	3	8	32	9	M8	81.5	181.4
MP-305-H	3/4"	43	109.5	109.5	96.5	80.5	3	9	32	9	M8	96.5	195.5
MP-306-H	1"	55	134.5	134.5	119	103	4	10	37	11	M10	119	224.5

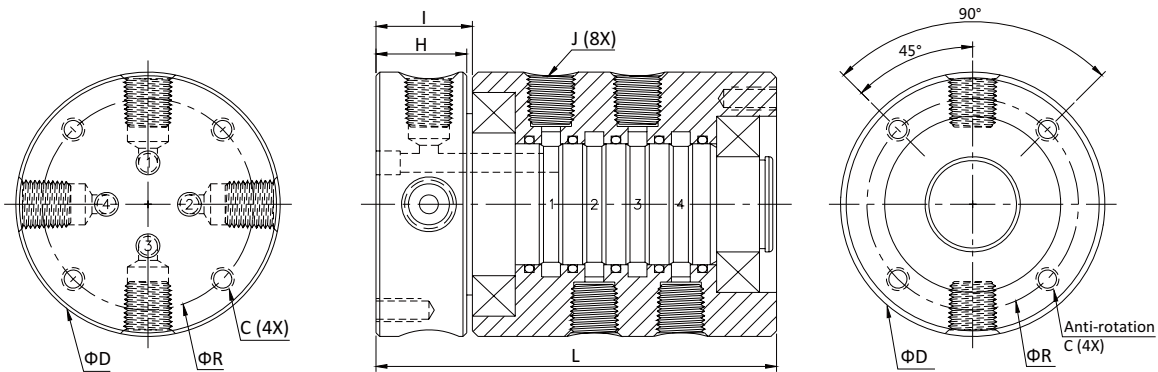

Part#	J(BSPP/NPT)	ΦR	C	ΦD	H	I	L
AP-301-H	1/8"	54	M6	64.5	19.5	20	127.4
AP-302-H	1/4"	59	M6	69.5	22.5	23	134.4
AP-303-H	3/8"	64	M6	74.5	28.5	29	154.9
AP-304-H	1/2"	77	M8	89.5	33.5	34	175.4
AP-305-H	3/4"	92	M8	104.5	42.5	43	206.4
AP-306-H	1"	105	M10	119.5	56.5	57	244.5